

## AE-SMDG-LC20

1.25G SFP Transceiver 1310nm 20km



Up to 20km transmission on SMF  
Up to 1.25 Gbps  
1310nm FP laser and PIN receiver  
2-wire interface for integrated Digital Diagnostic monitoring  
Hot pluggable  
Very low EMI and excellent ESD protection  
+3.3V power supply  
Power consumption less than 1.0W  
Operating case temperature: 0~+70°C

### PRODUCT PROFILE

AE-SMDG-LC20 is a high performance, cost effective modules, which is supporting up to 1.25Gbps, and transmission distance up to 20km on SM fiber. The transceiver consists of two sections: The transmitter section incorporates a laser driver and a 1310nm FP laser. The receiver section consists of a PIN photodiode integrated with a transimpedance preamplifier (TIA) and a Limiting

Amplifier. The module is hot pluggable into the 20-pin connector. The high-speed electrical interface is based on low voltage logic, with nominal 100Ohms differential impedance and AC coupled in the module.

The optical output can be disabled by LVTTTL logic high-level input of TX\_DIS. Transmit Fault (Tx\_Fault) is provided to indicate that the module transmitter has detected a fault condition related to laser operation or safety. Loss of signal (RX\_LOS)

output is provided to indicate the loss of an input optical signal of receiver. A serial EEPROM in the transceiver allows the user to access transceiver monitoring and configuration data via the 2-wire SFP Management Interface. This interface uses a single address, A0h, with a memory map divided into a lower and upper area. Basic digital diagnostic (DD) data is held in the lower area while specific data is held in a series of tables in the high memory area.

### APPLICATIONS

- High-speed storage area networks
- Computer cluster cross-connect
- Custom high-speed data pipes

### COMPLIANCE

- Compliant with IEEE 802.3Z
- Compliant with MSA SFF-8472
- Compliant with SFP MSA

**AE-SMDG-LC20**

1.25G SFP Transceiver 1310nm 20km

**SPECIFICATION**

**Absolute Maximum Ratings**

Parameter	Symbol	Min.	Max.	Unit	Notes
Storage Temperature	T <sub>s</sub>	-40	+85	°C	
Supply Voltage	V <sub>CC3</sub>	0	3.6	V	
Relative Humidity	RH	5	+85	%	Note1
Rx Input Average Power	P <sub>max</sub>	-	+1	dBm	

Notes:

[1] Non-condensing state.

**Recommended Operating Conditions**

Parameter	Symbol	Min.	Typical	Max.	Unit
Operating Case Temperature	T <sub>C</sub>	0	25	+70	°C
Power Supply Voltage	V <sub>CC3</sub>	3.13	3.3	3.47	V
	I <sub>CC3</sub>	-	-	300	mA
Power Dissipation	P <sub>D</sub>	-	-	1.0	W
Data Rate			1.25		Gbps

**Transmitter Operating Characteristic-Optical, Electrical**

Parameter	Symbol	Min.	Typical	Max.	Unit	Note
Centre Wavelength	λ <sub>C</sub>	1260	1310	1355	nm	
Spectral Width	Δλ			4	nm	FP (RMS)
Average Optical Power	P <sub>avg</sub>	-9	-	-3	dBm	
Laser Off Power	P <sub>off</sub>	-	-	-40	dBm	
Extinction Ratio	ER	8.2	-	-	dB	
Operating Data Rate		-	1.25	-	Gbps	
Optical Eye Mask	Complies with IEEE802.3z eye masks when filtered					
Tx Input Diff. Voltage	V <sub>I</sub>	500	-	2400	mV	
Tx Fault	V <sub>oL</sub>	-0.3	-	0.4	V	
	V <sub>oH</sub>	2.4	-	V <sub>CC</sub> +0.3		

**AE-SMDG-LC20**
**1.25G SFP Transceiver 1310nm 20km**
**Receiver Operating Characteristic-Optical, Electrical**

Parameter	Symbol	Min.	Typ.	Max.	Unit	Note
Center Wavelength	$\lambda_r$	1260		1620	nm	
Receive Sensitivity In Average Power	Psen	-	-	-22	dBm	
Los Assert	LosA	-35	-	-	dBm	
Los Dessert	LosD	-	-	-20	dBm	
Los Hysteresis	LosH	0.5	-	-6	dB	
Overload	Pin	-	-	-3	dBm	
Rx Output Diff Voltage	Vo	370	-	2000	mV	
Operating Data Rate	-	-	1.25	-	Gbps	

**Digital Diagnostic Functions**

Parameter	Symbol	Min.	Max.	Unit	Note
Temperature monitor absolute error	DMI_Temp	-3	3	°C	Over operating temp
Laser power monitor absolute error	DMI_TX	-3	3	dB	
RX power monitor absolute error	DMI_RX	-3	3	dB	
Supply voltage monitor absolute error	DMI_VCC	-3%	+3%	V	
Bias current monitor absolute error	DMI_Ibias	-10%	10%	mA	

**Control and Status I/O Timing Characteristics**

Parameter	Symbol	Min.	Max.	Unit	Note
TX Disable Assert Time	t_off	-	100	μs	Note1
TX Disable Negate Time	t_on	-	2	ms	Note2
Time to initialize including reset of TX_Fault	t_init	-	300	ms	Note3
TX Fault Assert Time	t_fault_on	-	1	ms	Note4
TX Fault Reset Time	t_reset	10	-	μs	Note5
LOS Assert Time	t_loss_on	-	100	μs	Note6

**AE-SMDG-LC20**

1.25G SFP Transceiver 1310nm 20km

LOS Deassert Time	t_loss_off	-	100	μs	Note7
-------------------	------------	---	-----	----	-------

Notes:

- [1] Time from rising edge of TX Disable to when the optical output falls below 10% of nominal
- [2] Time from falling edge of TX Disable to when the modulated optical output rises above 90% of nominal
- [3] From power on or negation of TX Fault using TX Disable
- [4] Time from fault to TX fault on
- [5] Time from TX fault to TX nominal
- [6] Time from LOS state to RX LOS assert
- [7] Time from non-LOS state to RX LOS deassert

**PIN-OUT DEFINITION**

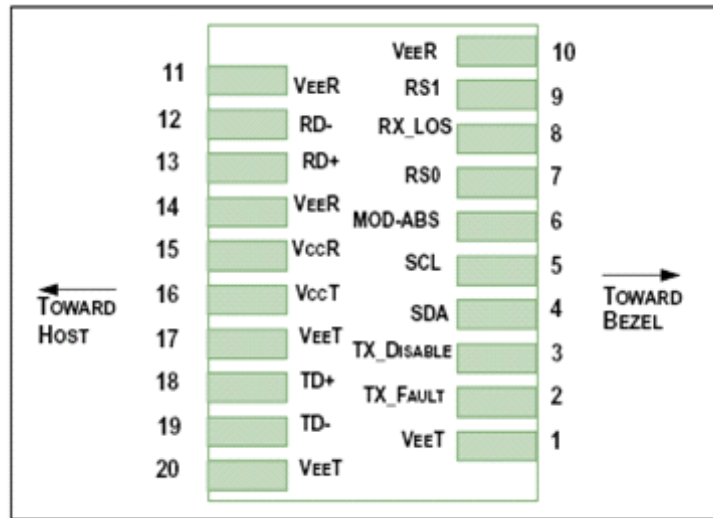

FIGURE 1

**AE-SMDG-LC20**

1.25G SFP Transceiver 1310nm 20km

**PIN ASSIGNMENT**

Pin	Logic	Symbol	Name/Description	Note
1		VeeT	Module Transmitter Ground	Note1
2	LVTTTL-O	TX_Fault	Module Transmitter Fault	Note2
3	LVTTTL-I	TX_Disable	Transmitter Disable; Turns off transmitter laser output	Note3
4	LVTTTL-I/O	SDA	2-wire Serial Interface Data Line (Same as MOD-DEF2 as defined in the INF-8074i)	Note4
5	LVTTTL-I/O	SCL	2-wire Serial Interface Clock (Same as MOD-DEF1 as defined in the INF-8074i)	Note4
6		MOD_ABS	Module Absent, connected to VeeT or VeeR in the module	Note5
7	LVTTTL-I	RS0	Not used	
8	LVTTTL-O	RX_LOS	Receiver Loss of Signal Indication (In FC designated as RX_LOS, in SONET designated as LOS, and in Ethernet designated at Signal Detect)	Note2
9	LVTTTL-I	RS1	Not used	
10		VeeR	Module Receiver Ground	Note1
11		VeeR	Module Receiver Ground	Note1
12	CML-O	RD-	Receiver Inverted Data Output	
13	CML-O	RD+	Receiver Non-Inverted Data Output	
14		VeeR	Module Receiver Ground	Note1
15		VccR	Module Receiver 3.3 V Supply	
16		VccT	Module Transmitter 3.3 V Supply	
17		VeeT	Module Transmitter Ground	Note1
18	CML-I	TD+	Transmitter Non-Inverted Data Input	
19	CML-I	TD-	Transmitter Inverted Data Input	
20		VeeT	Module Transmitter Ground	Note1

**AE-SMDG-LC20**

1.25G SFP Transceiver 1310nm 20km

**BLOCK DIAGRAM OF TRANSCEIVER**

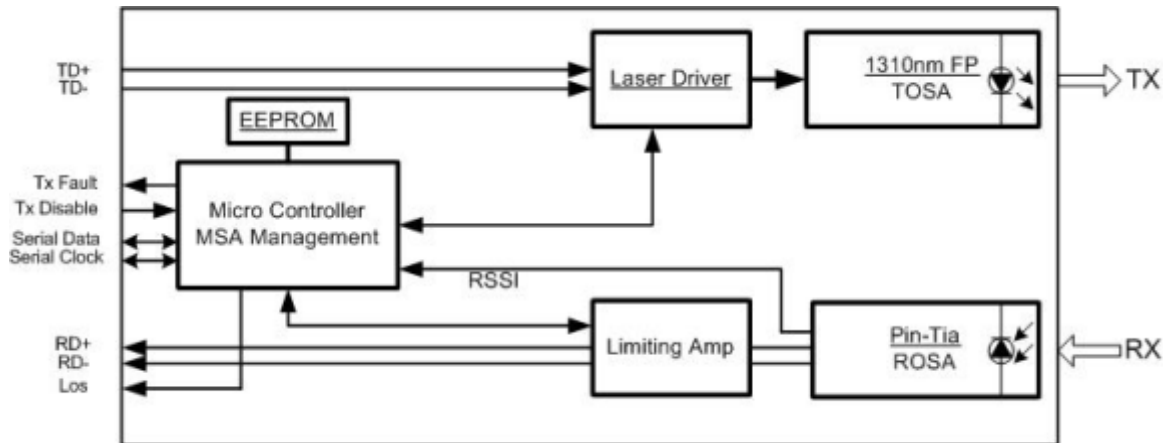

Figure2

**TRANSMITTER SECTION**

The transmitter converts 1.25Gbit/s serial PECL or CML electrical data into serial optical data compliant with the 1000BASE-LX standard. An open collector compatible Transmit Disable (Tx\_Dis) is provided. A logic "1," or no connection on this pin will disable the laser from transmitting. A logic "0" on this pin provides normal operation. The transmitter has an internal automatic power control loop (APC) to ensure constant optical power output across supply voltage and temperature variations. An open collector compatible Transmit Fault (Tx\_Fault) is provided. TX\_Fault is a module output contact that when high, indicates that the module transmitter has detected a fault condition related to laser operation or safety. The TX\_Fault output contact is an open drain/collector and shall be pulled up to the Vcc\_Host in the host with a resistor in the range 4.7-10 kΩ. TX\_Disable is a module input contact. When TX\_Disable is asserted high or left open, the SFP+ module transmitter output shall be turned off. This contact shall be pulled up to VccT with a 4.7 kΩ to 10 kΩ resistor

**RECEIVER SECTION**

The receiver converts 1.25Gbit/s serial optical data into serial PECL/CML electrical data. An open collector compatible Loss of Signal is provided. Rx\_LOS when high indicates an optical signal level below that specified in the relevant standard. The Rx\_LOS contact is an open drain/collector output and shall be pulled up to Vcc\_Host in the host with a resistor in the range 4.7-10 kΩ, or with an active termination. Power supply filtering is recommended for both the transmitter and receiver. The Rx\_LOS signal is intended as a preliminary indication to the system in which the SFP is installed that the received signal strength is below the specified range. Such an indication typically points to non-installed cables, broken cables, or a disabled, failing or a powered off transmitter at the far end of the cable.

**AE-SMDG-LC20**

1.25G SFP Transceiver 1310nm 20km

**RECOMMENDED INTERFACE CIRCUIT**

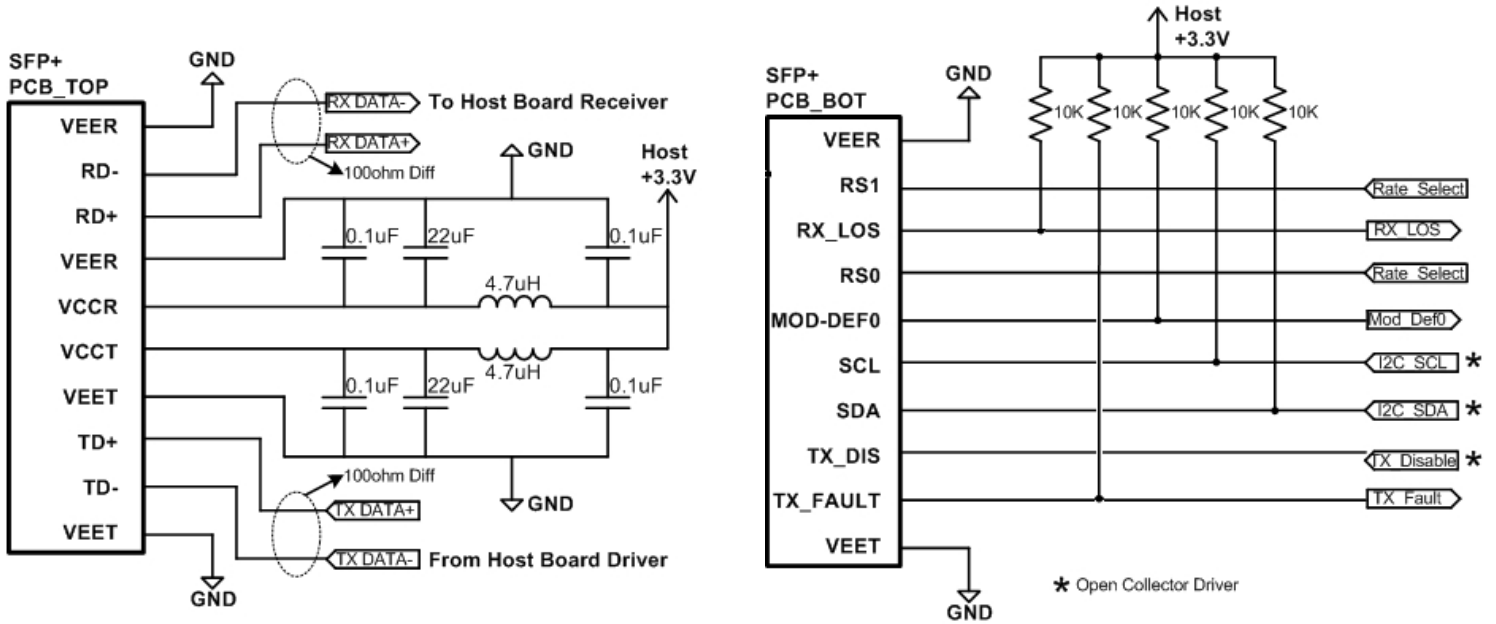

**DIMENSIONS**

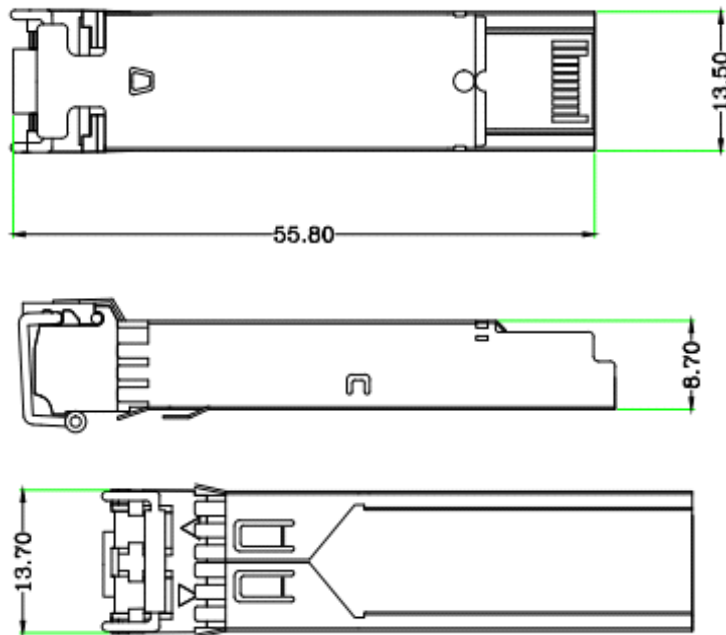

Figure 4

Tolerance: X.X±0.10 X.XX±0.05 X.XXX±0.01

**AE-SMDG-LC20**

1.25G SFP Transceiver 1310nm 20km

**DIGITAL DIAGNOSTIC MEMORY MAP**

